



AIRCRAFT CATERING HI-LIFT



Hi-end PLC Drop Cab (2,200mm to 6,000mm)



Drop Cab (2,200mm to 6,000mm)

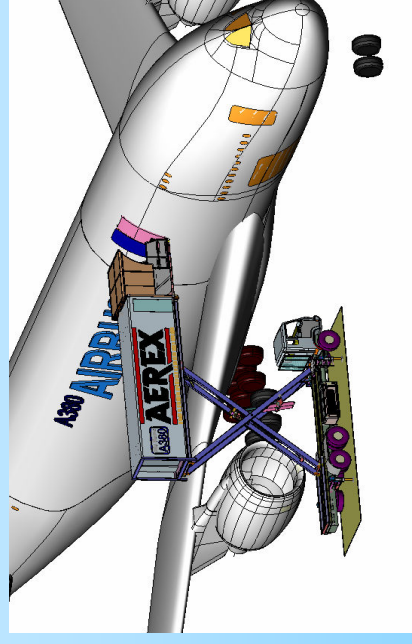

A380 Catering Hi-Lift (serves up to 8,200mm)



Standard Cab (2,650mm to 6,000mm)



Half Cab (1,550mm to 6,000mm)

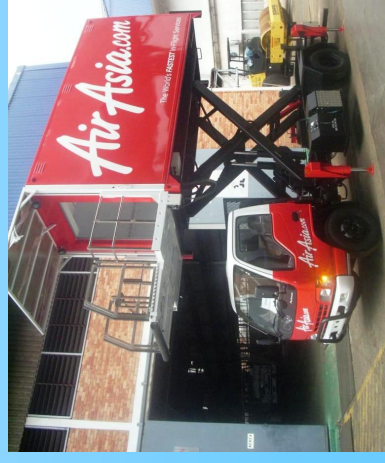

Mini Hi-Lift (2,400mm to 3,750mm)

CATERING HI-LIFT



GENERAL

The AEREX Standard Cab Catering Hi-Lift is designed to service aircraft with doorsill heights ranging from 2,650mm to 6,000mm. The unit has a load capacity of 4,000kg. To cater for a lower loading platform, the user can opt for a Drop Cab or a Half Can version. The Drop Cab version allows a loading height of 2,200mm and a Half cab version allows a loading height of 1,550mm. All units mentioned have a payload of 4,000kg.

A specially customized Mini-Hi-Lift is also offered for budget carriers which caters a loading height of 2,400mm to 3550mm and has a rated payload of 2000 kg.

TRUCK SYSTEM

Our hydraulic and electrical system have state-of-the-art design which offers easy trouble shooting and maintenance. We offer Solid State or a high end PLC (Programmable Logic Controller) to couple the truck system with the AEREX modules to form an AEREX product.



ELECTRICAL SYSTEM

The electrical systems are independent from the chassis electrical system. A master control switch links the electrical supply to the equipment control system via a circuit breaker. Circuits downstream the circuit breakers and are further protected individually by fuses. All control wirings are neatly labeled and converges in a centrally located terminal box. The option of PLC enables all operation functions/malfunctions to be checked ONLINE.

HYDRAULIC SYSTEM

The source of the hydraulic power is from the PTO directly coupled to the gear pump. A manual hand pump provides an alternative source of hydraulic power in the event of engine/pump failure. The system is controlled by electro-mechanical solenoid directional valve through toggle switches located on control panels. The directional control valves are centrally located for ease of accessibility to allow manual override in the event of power failure.

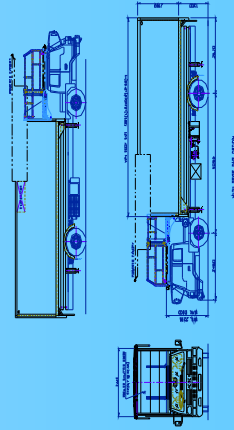

SAFETY FEATURES

Emergency push buttons are located at strategic control panels to stop operation during emergency. The transmission is interlocked to prevent the truck to be driven when stabilizers are extended. Pilot check valves ensure all cylinders stay in position. All conspicuous corners, edges and surfaces are rounded and smoothed for safe working. Additional safety interlocks or requirements can be incorporated to meet specific request.



AEREX SDN. BHD.
Gate 2, UMW Complex
Selangor , MALAYSIA.
Tel: +603 5163 5350
Fax:+603 5510 4381
Website: www.aerex.com.my



AIRCRAFT INVALID PASSENGER LIFT

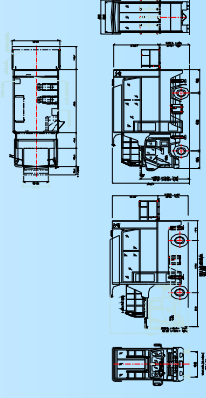

Platform Height Range

<u>Standard Cab</u>
Min. 2,650 mm
Max. 5,800 mm
<u>Drop Cab</u>
Min. 2,200 mm
Max. 5,800 mm

Chassis

Model	Isuzu FRR Series
GVW	12,000kg
Wheel Base	4,250mm

Features

- Side access door with stairwell
- Caged tail-lift which can raise/lower/fold/unfold
- Large tinted windows
- 2 way intercom
- FRP/Polyurethane/FRP wall and ceiling
- Moon matting floor

Optional Accessories

- Wheelchair and stretcher locking belts
- Extractor fan
- Air conditioner

INVALID PASSENGER LIFT



VAN BODY

A side door and a built-in internal staircase is provided with a 2 leaf sliding door at the front and rear of the van body. The van body also comes with an air conditioning system, interior lighting and a intercom to facilitate communication with the driver.

TAILGATE

A rear tailgate platform can be hydraulically lowered or raised from the ground to the van body floor. The tailgate can also be hydraulically folded and unfolded with ease



GENERAL

The AEREX Invalid Passenger Lift is used for transporting invalid or handicapped passengers using wheelchairs or stretchers while on transit between the aircraft and the passenger terminal building. The unit is capable of elevating to aircraft doors with sill heights of 2650 mm to 5800 mm.

For lower height requirements, the end user can opt for a Drop Cab version which caters for the height of 2200 mm to 5800 mm.

The double scissors and stabilizer assembly are constructed on a common sub-frame. A front loading platform above the cab rises at the same level as the van body floor to provide a level interface with aircraft doorills. The platform can be extended hydraulically to reach the aircraft door sill.



SAFETY FEATURES

Emergency push buttons are located at strategic control panels to stop operation during emergency. The transmission is interlocked to prevent the truck to be driven when stabilizers are extended and the tailgate is not stowed. Pilot check valves ensure all cylinders stay in position. All conspicuous corners, edges and surfaces are rounded and smoothened for safe working. Additional safety interlocks or requirements can be incorporated to meet specific request.



A door locking mechanism is incorporated when the van body raises as an added safety feature.



AEREX SDN. BHD.
Gate 2, UMW Complex
Jalan Utas 15/7, 40200 Shah Alam,
Selangor , MALAYSIA.
Tel: +603 5163 5350
Fax:+603 5510 4381
Website: www.aerex.com.my



AIRCRAFT LAVATORY SERVICING TRUCK

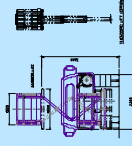
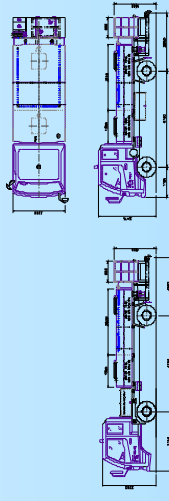

Chassis
 Model Isuzu NQR
 GVW 8700 kg
 Wheelbase 3365 mm
 Turning radius 6.2meter

Tank Capacity
 Waste 2300 litres
 Water 1100 litres
 Material S/Steel
 Thickness 6 mm

Pump
 Material S/Steel
 Flow rate 120L/min
 Pressure 35 psi
 Drive Hydraulic motor
 Hyd. source PTO pump

Vacuum System (Optional)
 Drive Hydraulic motor
 Type Liquid Ring
 Suction 15inHg vacuum

Lift Platform
 Material S/Steel tube frame and
 aluminum chequered floor
 Height 3000 mm (max)
 Limit Switch Antenna type
 Lift System Scissors lift

(For Reference Only. Pls. check with AEREX)

LAVATORY TRUCK



GENERAL

The AEREX Lavatory Servicing Truck is a self-contained unit consisting of a 2200 litre waste tank, 1300 litres water tank, water pump assembly, waste hose, water hose, hoses compartment and lift platform assembly. The scissor lift platform at the rear of the unit helps operators reach the aircraft's discharge port easily.

WASTE TANK & WATER TANK

The stainless steel tank is semi elliptical in shape and has two separate compartments, one for the water storage and one for waste storage.

The waste tank comes complete with an inspection manhole, a water flushing line to clean the interior of the tank, an intake port and a waste discharge valve.

The water tank comes complete with an inspection manhole, filling port, sight glass and outlet to the pump. The top surface of the tank is covered with anti-skid strips.



WATER PUMP ASSEMBLY

The hydrostatically driven, centrifugal pump is capable of delivering 120 litres/min at 35psi. The whole assembly, which includes control and regulating valves, is housed in a steel cabinet which is below the tank and beside the chassis. This is to allow accessibility and positive feed to the inlet of the pump.

VACUUM PUMP ASSEMBLY

The hydrostatically driven vacuum pump is capable of sustaining a 20 inchHg negative displacement in the tank. Free air delivery of the vacuum pump is at 2000 litres/min. Suction is carried by opening the ball valve situated at the lift platform. For discharging, a positive feed 0.7 bar is applied to the tank to speed up the discharging process.

LIFT PLATFORM

The lift platform at the rear of the truck is constructed from stainless steel tube frames and an aluminum floor plate. The platform control panel, flow meter, water hose coupler, swivel working spotlight and an antenna type safety limit switch are located on the lift platform. A stowage compartment for the waste hose is also located here.



AEREX SDN. BHD.
Gate 2, UMW Complex
Jalan Utas 15/7, 40200 Shah Alam,
Selangor , MALAYSIA.
Tel: +603 5163 5350
Fax: +603 5510 4381
Website: www.aerex.com.my



AIRCRAFT WATER SERVICING TRUCK

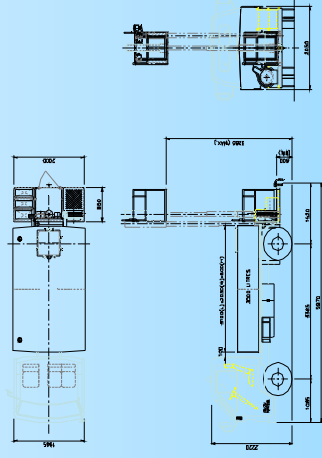

Tank Capacity / Construction

Water 3000 litres
 Material S/Steel
 Thickness 4.5 mm

Chassis

Model Isuzu NQR
 GVW 8700 kg
 Wheelbase 3365 mm

Pump

Material S/Steel
 Flowrate 120 litre/min
 Pressure 50 psi
 Drive Hydraulic motor
 Hyd. source PTO pump

Lift Platform

Material S/Steel tube frame and
 aluminum chequered floor
 Height 3000 mm (max)
 Limit Switch Antenna type
 Lift System Scissors lift

(For Reference Only. Pls. check with AEREX)

WATER TRUCK



GENERAL

The AEREX Water Servicing Truck is a self-contained unit consisting of a stainless steel water tank, assembly and lift platform. The tank interior is smoothed and coated with food grade paint. It is formed from a 4.5 mm stainless steel with ends dished outwards to take water surge. Special attention is laid on the tank design to avoid cavities which can trap dirt and is ideal for bacteria breeding.

The scissor lift platform at the rear of the unit helps operators reach the aircraft's water filling port easily.

WATER TANK

The stainless steel tank is semi elliptical in shape and comes complete with two inspection manholes, a filling port, a level indication sight gauge and an accessible drain valve.

The manhole is designed to allow cleaners to enter the tank for inspection and manually clean the internal surfaces.

The top surface of the tank is covered with anti-skid strips.

WATER PUMP ASSEMBLY

The whole assembly, which includes control and regulating valves, is housed in a compartment below the tank and beside the chassis. This is to allow accessibility and positive feed to the inlet of the pump.

The centrifugal stainless steel water pump is hydrostatically driven by a hydraulic motor. The water pump is regulated to deliver 30 US gal/min at 50 psi.

LIFT PLATFORM

The lift platform at the rear of the truck is constructed from stainless steel tube frames and an aluminum floor plate. The platform control panel, flow meter, water hose coupler, swivel working spotlight and an antenna type safety limit switch are located on the lift platform.



AEREX SDN. BHD.
Gate 2, UMW Complex
Jalan Utas 15/7, 40200 Shah Alam,
Selangor, MALAYSIA.
Tel: +603 5163 5350
Fax: +603 5510 4381
Website: www.aerex.com.my





AIRCRAFT PASSENGER STAIRS

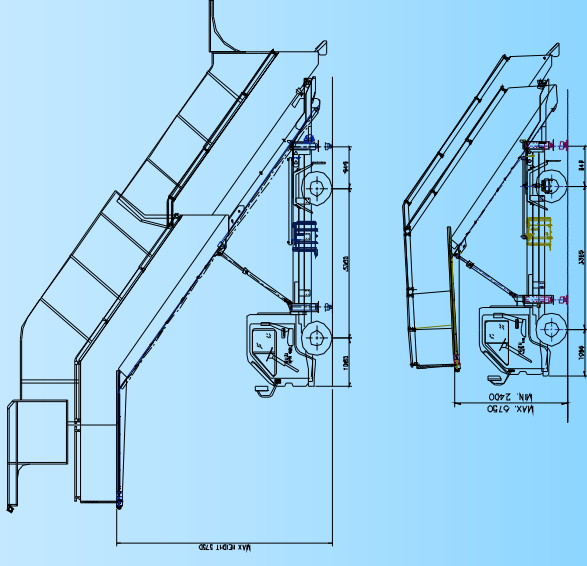
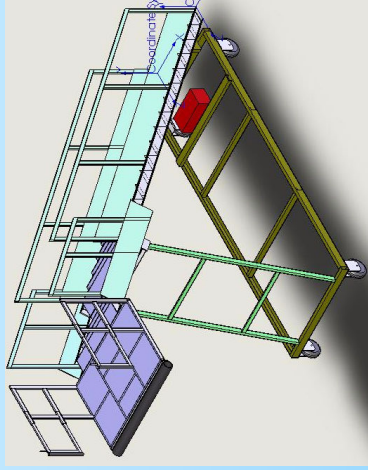
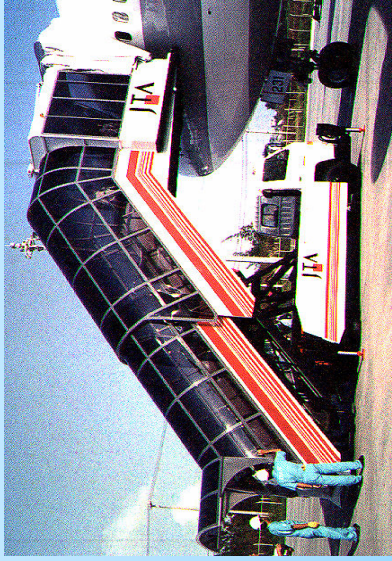

Fixed Passenger Staircase



Open type (without canopy)



Canopy with vestibule interfacing



Canopy with sliding interfacing

PASSENGER STAIRS

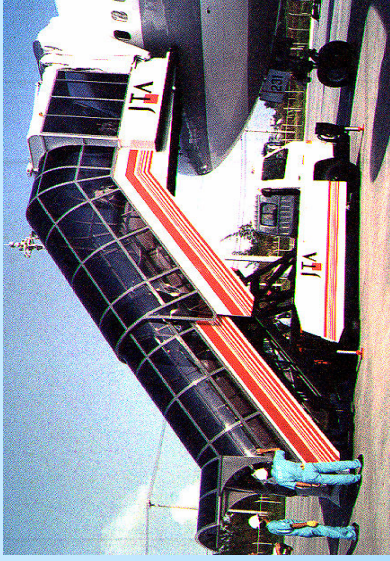

GENERAL

The AEREX Passenger Stairs is designed to service aircraft doorsill heights of 2400 mm to 5750 mm.

The user can opt for a VIP type totally enclosed canopy with choice of interfacing to the aircraft door opening –either collapsible vestibule or sliding fixed canopy.

The frame is designed to allow it to be mounted on any suitable commercial chassis. It is made from steel structures and is externally finished with aluminum panels.

The steps and platform flooring are constructed from aluminum chequered plates with extrusion nose lining the forward edge of each bend.

THE PLATFORM

The user can apply the micro-height adjustment located at the platform control panel to align the slope inclination of the platform to the aircraft doorsill height. This is facilitated by the action of two hydraulic cylinders of the slope frame assembly. Pilot check valves ensures the hydraulic cylinders stay in position once control is deactivated.



THE STAIRS

The stairs assembly consist of moveable upper stairs and fixed lower stairs. The upper stairs assembly is designed to extend in a telescopic manner to cater for varying height requirement. A step ratchet lock mechanism locks the upper stairs when located in position. It also ensures that the upper and lower stairs assembly is spaced in full steps configuration.

To illuminate the steps in night operation, lighting is lined on the sidewalls of the steps and platform area. Stabilizers on the main frame provide the rigidity to the complete stairs assembly.

FIXED & VARIABLE PASSENGER STAIRCASE

The AEREX Fixed Passenger is the other option of a towable, parallelogram passenger boarding stairway. This stairway has a rigid axle with castor wheels on the plane side.

It is equipped with 4 stabilizers, illumination and handrails on the leading platform. All corners are protected in rubber as a precaution.

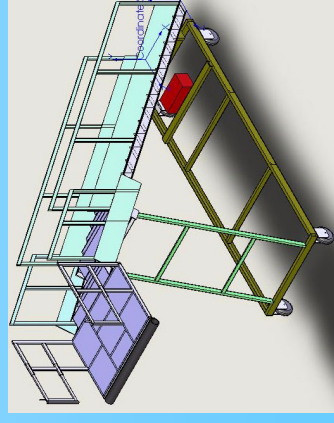

AEREX SDN. BHD.
Gate 2, UMW Complex
Jalan Utas 15/7, 40200 Shah Alam,
Selangor , MALAYSIA.
Tel: +603 5163 5350
Fax:+603 5510 4381
Website: www.aerex.com.my



AIRCRAFT MAINTENANCE PLATFORM

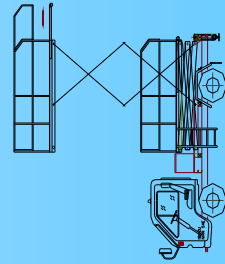
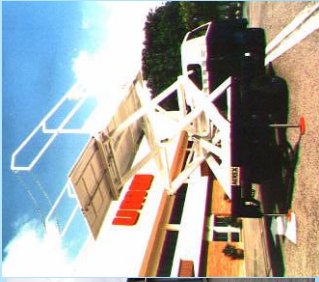

4.6 Meter

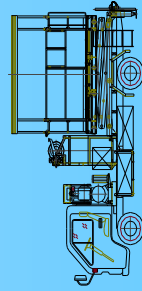

5 Meter

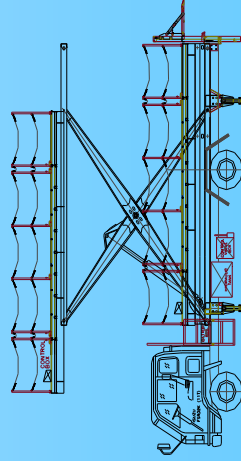

6 Meter

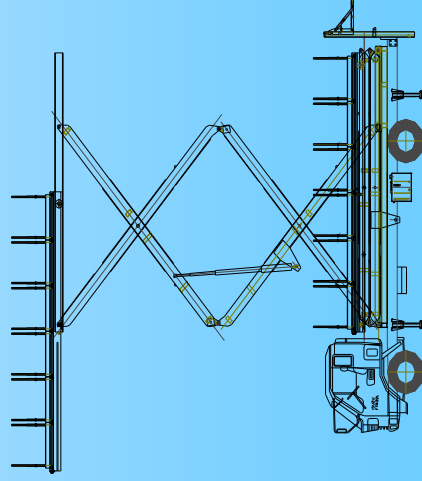

7 - 9 Meter

MAINTENANCE PLATFORM



GENERAL

The AEREX 4.5m to 9m Maintenance Lift Platform is designed to facilitate good access for aircraft maintenance. It incorporates a forward platform shift that moves the platform forward to narrow the gap with the aircraft.

Side extensions are also provided on the longitudinal side of the platform for closer reach to the aircraft fuselage.

The unit consist of a chassis cab, outriggers, a hydraulically powered double scissors lift mechanism, a main platform with hydraulically operated forward shift and manually operated side platform extensions on each side. A hydraulically operated tailgate (tail lift) to facilitate lifting of material form ground level to platform and vice-versa.

PLATFORM

The platform is raised by a double scissors mechanism by action of two telescopic hydraulic cylinders. Pilot check valves, flow control, etc. are installed as a standard safety requirement

The platform is lined with aluminum chequered plates. Safety railings (either collapsible type or rigid type) are installed on the four sides of the platform. Platform edges are cushioned with tubular rubber bumpers.



AEREX SDN. BHD.

Gate 2, UMW Complex

Jalan Utas 15/7, 40200 Shah Alam,

Selangor , MALAYSIA.

Tel: +603 5163 5350

Fax:+603 5510 4381

Website: www.aerex.com.my



BAGGAGE TROLLEY



Specification

Payload	2,500 kg
Steering System	Turntable
Towing Speed	40 km/h
Parking Brake	Tow Bar Actuated
O/A Height	1,905 mm
O/A Length	2,473 mm
O/A Width	1,575 mm
Body Base Height	610 mm
Min. Towing Height	300 mm
Tires (U-Lug)	Solid Cushion Type
Coupling System	Tow Hitch

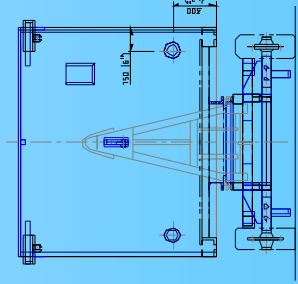
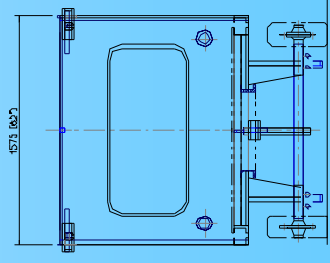
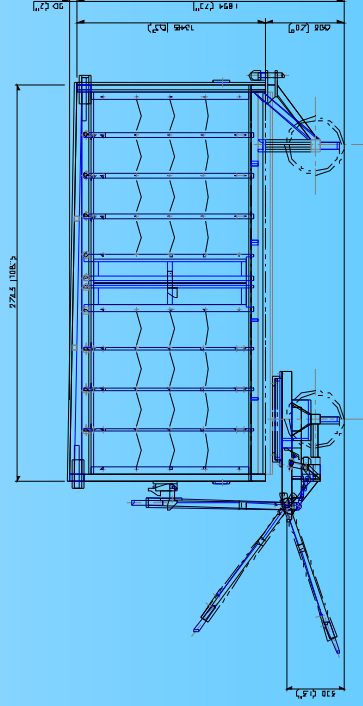

BAGGAGE TROLLEY



GENERAL

The AEREX baggage trolley specifications are for a standard version. Baggage Trolley can be tailored to meet individual requirement.

The trolley is designed for transportation of baggage and light cargo with a minimum payload of 2500 kg.

The trolley is rugged and is suitable and treated for outdoor use.

The design is suitable to be towed (up to 4 trolleys) at 40 km/h on bitumen Roads.

TECHNICAL DATA FOR AEREX BAGGAGE TROLLEY (For Reference Only. Pls. check with UMW)

	SPECIFICATION
Unladen Weight Payload	1,000 kg (approx.) 2,500 kg
Steering System	Tow bar on ball race type turn able
Towing Speed	40 km/h
Parking Brakes	Tow bar actuated
Overall Dimensions: ● Length ● Width ● Height	2,473 mm 1,575 mm 1,905 mm
Minimum Towing Height	30 mm from ground
Tyre (U-Lug)	Pneumatic Tyres

AEREX SDN. BHD.
Gate 2, UMW Complex
Jalan Utas 15/7, 40200 Shah Alam,
Selangor , MALAYSIA.
Tel: +603 5163 5350
Fax:+603 5510 4381
Website: www.aerex.com.my



PALLET DOLLY

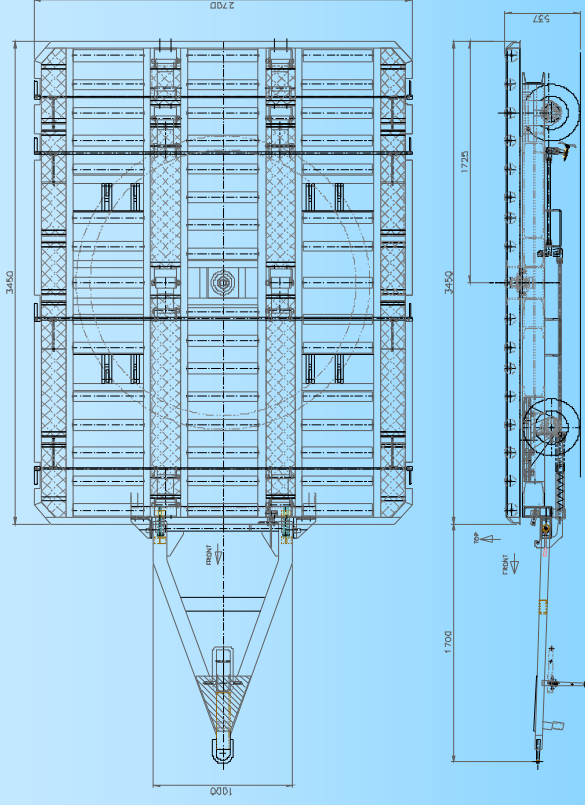
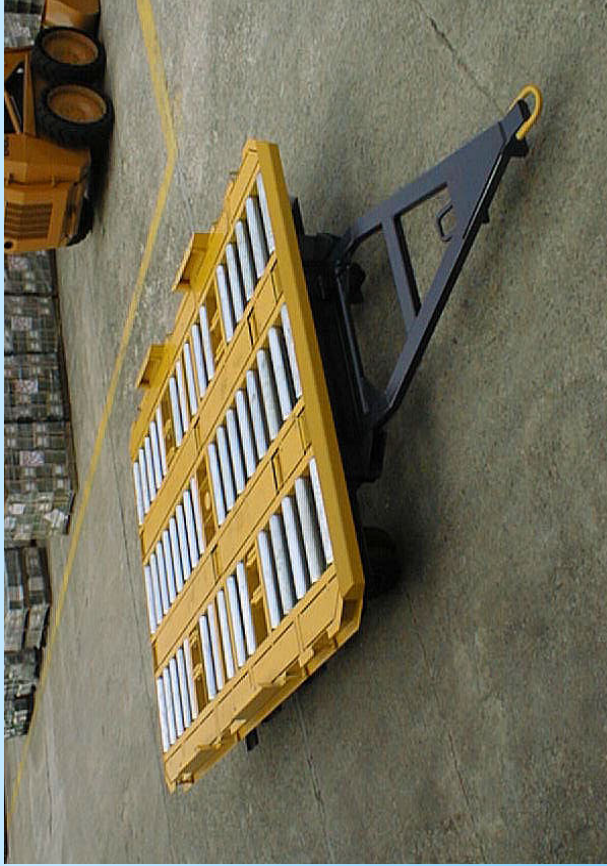

PALLET DOLLY



GENERAL

The AEREX pallet dollies specifications are for a standard version. Pallet Dollies can be tailored to meet individual requirement.

The pallet dollies are used for transportation of unitized cargo with a minimum payload of 7000kg.

The dolly is rugged and is suitable and treated for outdoor use.

It is capable of handling LDs ranging from LD1 to LD10.

The construction of the dolly is from steel frames fitted with gravity rollers. Locking of pallets and LDs are by means of butterfly locks and side restrains.

The front wheels are of swiveled type and rear fixed. Steering is done through the 2 front swivel wheels maintaining identical tracking when being towed.



TECHNICAL DATA FOR AEREX PALLET DOLLEY (For Reference Only. Pls. check with UMW)

	SPECIFICATION
Unladen Weight Payload	1,000 kg (approx.) 2,500 kg
Steering System	Tow bar on ball race type turn able
Towing Speed	40 km/h
Parking Brakes	Tow bar actuated
Overall Dimensions: ● Length ● Width ● Height	2,473 mm 1,575 mm 1,905 mm
Minimum Towing Height	30 mm from ground
Tyre (U-Lug)	Pneumatic Tyres

AEREX SDN. BHD.

Gate 2, UMW Complex
Jalan Utas 15/7, 40200 Shah Alam,
Selangor , MALAYSIA.
Tel: +603 5163 5350
Fax:+603 5510 4381
Website: www.aerex.com.my